

الاسم:
الرقم:

مسابقة في مادة الفيزياء
المدة : ساعتان

*This exam is formed of three obligatory exercises
in three pages numbered from 1 to 3.
The use of non-programmable calculators is allowed.*

First Exercise (7 points) Verification of Newton's second

In order to verify Newton's second law related to the dynamics of a solid in translation, we consider a puck of center of inertia G and of mass $M = 200$ g, a horizontal air table, a solid (S) of mass $m = 50$ g, an inextensible string and a pulley of negligible mass. We build the set up represented in the adjacent figure.

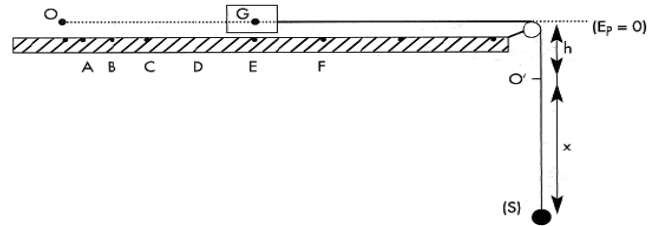

The part of the wire on the side of the puck is taut horizontally and the other part to the side of (S) is vertical.

The horizontal plane passing through G is taken as the gravitational potential energy reference.

At the instant $t = 0$, G is at O and the center of mass of (S) is at O', at a distance

h below the reference. We release (S) without initial velocity, and, at the same time, the positions of G are recorded at successive instants separated by a constant time interval $\tau = 50$ ms. At the instant t , G acquires a velocity \vec{V} and (S) is found at a distance x below O'.

Neglect all frictions and take $g = 10 \text{ m/s}^2$.

- A- 1) Give the expression of the mechanical energy of the system (puck, string, (S), Earth) in terms of M , m , x , h , V and g . This energy is conserved. Why?
- 2) Deduce the expression of the acceleration of (S) in terms of g , m and M and calculate its value.
- 3) Draw a diagram showing the forces acting on the puck and determine, using the relation $\sum \vec{F} = M\vec{a}$, the force \vec{T} exerted by the string on the puck.

B- By means of a convenient method, we determine the speed V of the puck. The results are tabulated as shown below:

Point	A	B	C	D	E
t in ms	50	100	150	200	250
V in cm/s	10	20	30	40	50

Determine, using the table, the linear momentums \vec{P}_B at B and \vec{P}_D at D and determine the ratio

$$\frac{\Delta \vec{P}}{\Delta t} = \frac{\vec{P}_D - \vec{P}_B}{\Delta t}$$

C- Compare $\frac{\Delta \vec{P}}{\Delta t}$ and \vec{T} . Is Newton's second law thus verified? Justify.

Second Exercise (6 points) Determination of the capacitance of a capacitor

In order to determine the capacitance C of a capacitor, we connect up the circuit of figure 1. This circuit is formed of the capacitor, a generator of e.m.f. $E = 9\text{ V}$ and of negligible internal resistance, two resistors of resistances $R_1 = 200\text{ k}\Omega$ and $R_2 = 100\text{ k}\Omega$ and two switches K_1 and K_2 .

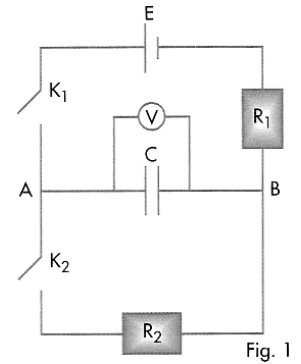

I- Charging the capacitor

The capacitor being initially uncharged, we close K_1 and keep K_2 open. The capacitor will be charged.

1) Derive the differential equation that describes the variation of the voltage $v_C = v_{AB}$ across the capacitor.

- 2) Knowing that the solution of this differential equation has the form $v_C = E(1 - e^{-\frac{t}{\tau_1}})$ expression of the constant τ_1 as a function of R_1 and C .
- 3) Knowing that, at the instant $t_1 = 20\text{ s}$, v_C has a value of 7.78 V , calculate the capacitance C of the capacitor.

II-Discharging the capacitor

The capacitor being charged under a voltage of 9 V , we open K_1 and close K_2 .

The capacitor then discharges.

- 1) Draw a diagram of the circuit during that phase indicating the direction of the current.
- 2) Derive the differential equation that describes the variation of the voltages $v_C = v_{AB}$ across the capacitor.
- 3) Knowing that the solution of this differential equation is of the

form $v_C = E e^{-\frac{t}{\tau_2}}$, deduce the expression of:

- a) the current i as a function of time. Take the direction of the current as a positive direction.
- b) the time constant τ_2 as a function of R_2 and C .
- 4) A convenient apparatus allows us to trace the graph of the variation of v_C as a function of time. (fig. 2)

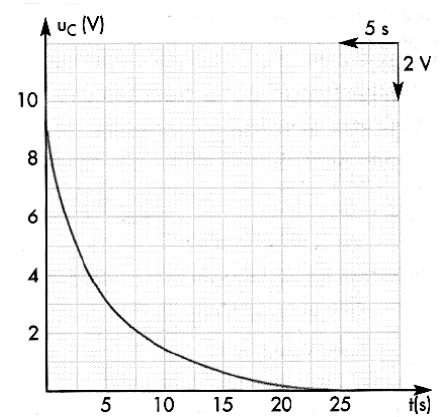

Determine from the curve the value of τ_2 . Deduce the value of C .

III- What conclusion can be drawn about the two values of C ? Comment.

Third Exercise (6 points) Controlled nuclear reaction

A chain nuclear reaction releases a considerable amount of energy. It may lead to an explosion if precautions were not taken. If this reaction is controlled inside a reactor, it may produce energy enough to function an electric power plant.

A- In a nuclear reactor of an atomic pile, the preparation of uranium 235, used as a fuel, takes place as follows:

- 1) The uranium nucleus ${}_{92}^{238}\text{U}$ captures a fast neutron and is transformed into a uranium nucleus ${}_{92}^{239}\text{U}$.

Write the corresponding reaction.

- 2) The uranium nucleus 239 is radioactive, it is transformed into plutonium after two successive β^- dis-integrations according to the following reactions:

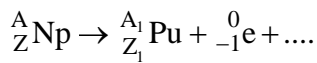
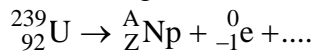

Complete these reactions and determine Z, A, Z_1 and A_1 specifying the supporting laws.

- 3) The radioactive plutonium nucleus (Pu) is an α emitter. The daughter nucleus is the uranium 235 isotope. Some α particles are ejected with a kinetic energy of 5.157 MeV each and others with a kinetic energy of 5.144 MeV each.
- a) Write the equation of the disintegration of (Pu) nucleus.
- b) One of these α disintegrations is accompanied by the emission of a photon γ . Calculate the energy of this photon and deduce the wavelength of the associated radiation.
- 4) Uranium 235 is fissionable. During one of these possible fission reactions, the mass defect is 0.2 u. Calculate, in MeV and in J, the energy liberated by the fission of one nucleus of uranium 235.

B- In that atomic pile, a mass of 0.4 kg of uranium 235 is consumed in one day. The efficiency of the transformation of nuclear energy into electric energy is 30%. Calculate the electric power of this pile.

Given:

- $1 \text{ u} = 1,67 \times 10^{-27} \text{ kg} = 931,5 \text{ MeV}/c^2$
- $c = 3 \times 10^8 \text{ m/s}$
- Molar mass of ${}^{235}\text{U} = 235 \text{ g}\cdot\text{mol}^{-1}$
- Avogadro's constant: $N = 6,02 \times 10^{23} \text{ mol}^{-1}$
- $1 \text{ MeV} = 1,6 \times 10^{-13} \text{ J}$
- Plank's constant $h = 6,63 \times 10^{-34} \text{ J}\cdot\text{s}$.